

Measurement Methods

Warning

- ◇ Applying voltage to the resistance measurement terminal immediately after switching to the resistance measurement function from another function may result in damage. Therefore, use adequate caution. To prevent damage, this product has a protective function that automatically measures the voltage under (DC+AC)V and displays a message if it detects a high voltage. The default setting for this voltage check function is ON. To switch this function off, change the VoltCheck system setting to OFF. See section 4.10.10 for details and for the procedure for switching the function off. If a voltage exceeding approximately 100V is detected by the (DC+AC) V function, “!Voltage_Detect” will be displayed and the product will forcefully return to the original function. However, this protective operation is not guaranteed for voltages with high frequencies or large peaks that are not guaranteed by (DC+AC)V. In addition, measurements cannot be taken correctly under conditions in which voltage is applied to the diode being tested. Therefore, when testing a diode within a circuit, make sure that voltage is not being applied to the diode being tested.

4.2.9 dB measurements



Pressing the **dBm** key while in DCV, ACV, (DC+AC)V or CH-B DCV mode enables dB measurements to be carried out. For details of a set parameter etc. of the dB measurement (standard resistance and standard voltage value), see 4.4.6. Decibel calculations.

◆ Pre-operation preparation

Connection method Refer to the precautions related to connecting the test leads in 4.1.4.

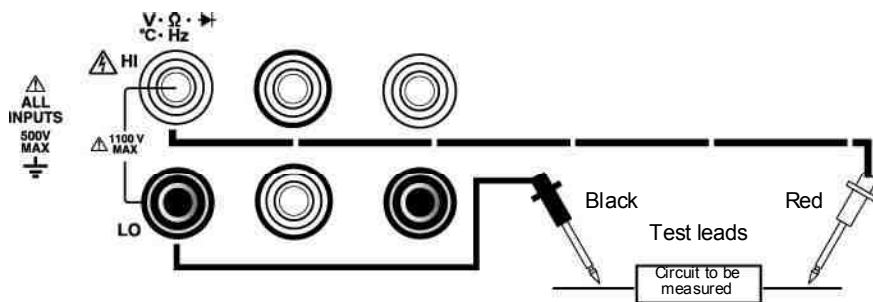

- Connect the black measuring lead to the LO terminal and the circuit being measured.
- Connect the red lead to the $V \cdot \Omega \cdot Hz$ terminal and to the circuit being measured.

Operating procedure

① Specify each measurement of DCV (Refer to section 4.2.1), ACV (Refer to section 4.2.2), (DC+AC) V (Refer to section 4.2.2), and CH-B DCV (Refer to section 4.2.10).

② Press the **AUTO** key or the and keys to specify the optimum range.

③ Press the **SHIFT** key and it will flash.

④ Press the **dBm** key.

Either of three following menus is displayed.



- dB:MOD = dBm/dBV
- dB:dBm – REF = 600Ω
- dB:dBV – REF = 1.0V

⑤ Press the and keys and select either of MOD, dBm-REF or dBV-REF.

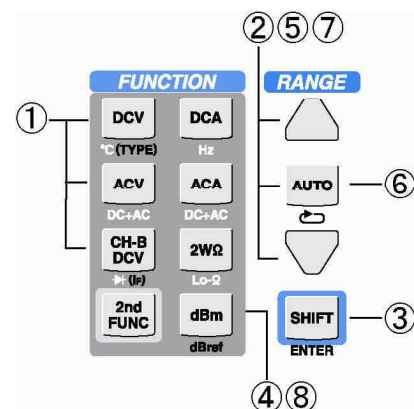
⑥ Press the **AUTO** key so that Set value of resistance or voltage in the right of the above-mentioned flashes.



Measurement Methods

⑦ Use the  and  range keys to select the reference resistance value or the reference voltage value .

⑧ Press the  key to implement the dBm calculation.

4.2.10 DC voltage measurement (CH-B DCV, VOAC7520H / 7523H only)

Three DCV measurement ranges can be selected from 5V, 50V, 300V. Since CH-B is isolated from CH-A, it is possible to simultaneously measure the voltage in two places that differ from the LO potential.

◆ Pre-operation preparation

Connection method Refer to the precautions related to connecting the test leads in 4.1.1

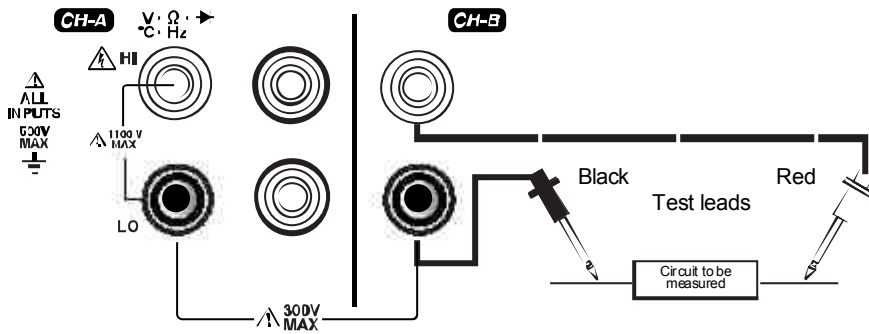

- Connect the black measuring lead to the CH-B LO terminal and the circuit being measured.
- Connect the red measuring lead to the CH-B HI terminal and the circuit being measured.

Operating procedure

- ① Press the **CH-B DCV** key to cause the key to light up and specify Channel B DCV.
- ② Press the **AUTO** key or the and keys to select the optimum range.

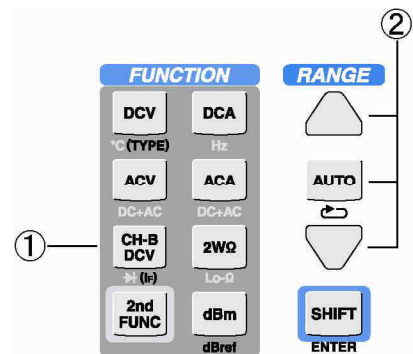

CAUTION!!

- ◇ The isolation resistance for CH-A and CH-B is DC \pm 300V.
- ◇ When using isolated, the multimeter is affected by the potential difference between CH-A Lo and CH-B Lo (refer to performance in Chapter 6).



4.3 Dual FUNCTION

During Dual FUNCTION operation, the system alternately switches between two measurement functions to perform measurement, while simultaneously displaying the measurement results. This function can be used, for example, to simultaneously measure voltage and current or voltage and frequency. Especially for models (VOAC7520H, VOAC7523H) that have an isolated direct current voltage measurement channel (CH-B DCV), this function can be used to compare the voltages of different circuits or easily measure the potentials of different components in the same circuit.

Below, in addition to the Dual FUNCTION, the term Single FUNCTION is used to refer to using one function to perform normal measurement.

Operating procedure

Switching between single and Dual FUNCTION operation

Each time  the key is pressed, the operation switches between single and Dual FUNCTION operation.  While Dual FUNCTIONS are used to perform measurement, the  key lights up. In addition, the display is split into a left and right area, and the two measurement results are simultaneously displayed.

The measurement function for which results are displayed on the left side is called the *main function*, and the function for which results are displayed on the right is called the sub function. When operation is switched from single to Dual FUNCTION operation, the function that performs measurement during Single FUNCTION operation is assigned to the main-function side of Dual FUNCTIONS. Similarly, when operation is switched from dual to Single FUNCTION operation, the function assigned to the main-function side is used for Single FUNCTION measurement.

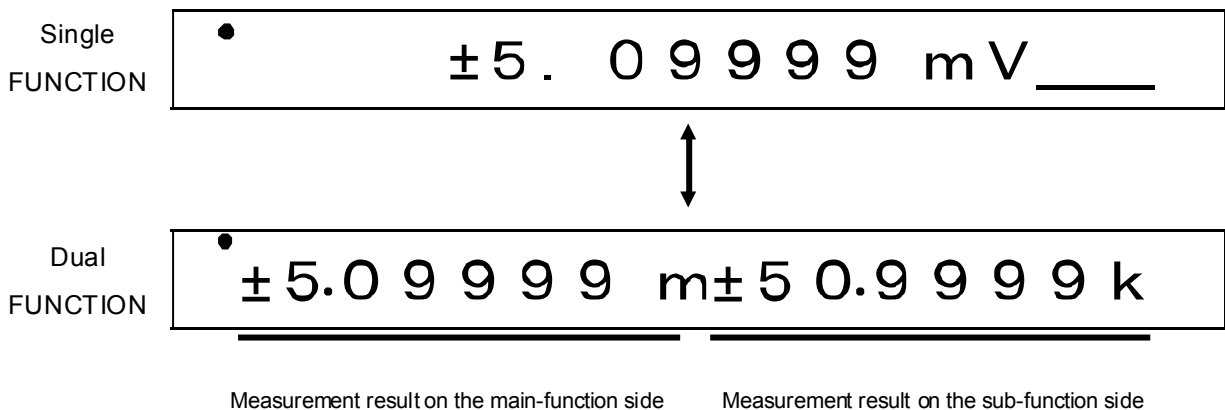

CAUTION!!

Unlike Single FUNCTION operation, the following restrictions apply during Dual FUNCTION operation:

- The sampling rate slows down because it is necessary to wait for the internal circuit to stabilize when the



function is switched.

- Comparator calculation results, types of statistical data, functions, ranges, and timestamp attribute information are not displayed.
- No measurement units are displayed on the main-function side. The measurement units for the sub-function area are indicated by the SUB DISP UNITS LEDs.

4.3.1 Dual FUNCTION operation

During Dual FUNCTION operation, when settings such as those for the measurement function, range, or calculation utility are changed, whether the changes are to be applied to the main function or sub function must be selected in advance. You can check which function is currently selected based on whether the MAIN DISP LED or SUBDISP LED is lit (as described in section 4.4.3). The procedure for changing settings is the same as that used during Single FUNCTION operation, but the changes are only applied to the function for which the LED is lit.

Note that the Dual FUNCTION selection menu can also be used to select the measurement function during Dual FUNCTION operation. (For details, see section 4.3.3.)

To switch the current function, press the  key. Each time the  key is pressed, the current function switches between the main function and sub function.

Here, whether the keys that indicate whether the measurement function or calculation utility is on or off are lit is determined by the settings for the currently selected function.

CAUTION!!

The following restrictions apply to the settings for the measurement function and calculation utility during Dual FUNCTION operation:

- Certain function combinations cannot be specified. (For details, see section 4.3.2.)
- Depending on the function combination, there might be measurement limitations. (For details, see section 4.3.2.)
- The main-function settings for the statistical calculation mode and number of samples apply to both the main and sub functions.

Measurement Methods

4.3.2 Dual FUNCTION combinations

The following restrictions apply to the measurement functions that can be assigned to the main side and sub side during Dual FUNCTION operation:

- The same measurement function cannot be assigned to both the main side and sub side.
- Function combinations that might damage this product cannot be specified.
- Depending on the combination, there might be measurement limitations.

The following table shows the limitations for combinations of measurement functions.

O: Possible X: Not possible Δ : Limitations exist.*1

MAIN \ SUB	DCV	CH-B DCV*2	ACV	(DC+AC) V	DCA	ACA	(DC+AC) A	2W Ω	4W Ω *3	Hz	°C
DCV		O	Δ^1	Δ^1	Δ^3	Δ^2	Δ^2	X	X	Δ^1	Δ^5
CH-B DCV*2	O		O	O	O	O	O	O		O	O
ACV	Δ^1	O		O	Δ^4	Δ^4	Δ^4	X	X	O	X
(DC+AC)V	Δ^1	O	O		$\Delta^{3,4}$	$\Delta^{3,4}$	$\Delta^{3,4}$	X	X	O	X
DCA	Δ^3	O	Δ^4	$\Delta^{3,4}$		Δ^2	Δ^2	Δ^3	Δ^3	O	X
ACA	Δ^2	O	Δ^4	$\Delta^{3,4}$	Δ^2		O	Δ^3	Δ^3	Δ^4	X
(DC+AC)A	Δ^2	O	Δ^4	$\Delta^{3,4}$	Δ^2	O		Δ^3	Δ^3	Δ^4	X
2W Ω	X	O	X	X	Δ^3	Δ^3	Δ^3		Δ^6	X	X
4W Ω *3	X		X	X	Δ^3	Δ^3	Δ^3	Δ^6		X	X
Hz	Δ^1	O	O	O	O	Δ^4	Δ^4	X	X		X
°C	Δ^5	O	X	X	X	X	X	X	X	X	

*1 In the table, the superscript to the right of the Δ mark indicates the number of a limitation described below.

*2 CH-B DCV is only installed in VOAC7520H / 7523H.

*3 4W Ω is only installed in VOAC7521H / 7522H.

CAUTION!!

Limitations on the Dual FUNCTION

- 1) When performing measurement by using the Dual FUNCTION combination DCV and ACV (or (DC+AC)V) and using the V pin and LO pin as shared input pins, the DCV accuracy is affected by the rejection performance (NMRR) for the ACV included in the measured signal. Therefore, for a FAST sample that does not have rejection or a measured signal other than that of the power supply frequency, measurement is not stable and the accuracy is not guaranteed.

Using the Dual FUNCTION combination ACV and (DC+AC)V is effective for measuring such signals or performing measurement when the AC component is dominant.

- 2) When performing measurement by using the Dual FUNCTION combination DCA and ACA (or (DC+AC)A) and using the mA pin or 10A pin and LO pin as shared input pins, the DCA accuracy is determined by the rejection performance (NMRR) for the ACA included in the measured signal. Therefore, for a FAST sample that does not have rejection or a measured signal other than that of the power supply frequency, measurement is not stable and the accuracy is not guaranteed.

Using the Dual FUNCTION combination ACA and (DC+AC)A is effective for measuring such signals or performing measurement when the AC component is dominant.

- 3) When using Dual FUNCTION to measure the voltage (or two-wire resistance) and current by using the V (or Ω) pin, mA or 10A pin, and LO pin as input pins, the voltage drop due to the measured current flowing through the LO wire affects the accuracy of the voltage (or resistance) measurement.

The (measured current) \times ($R_t + r$) (V) is added to the voltage measurement error, where R_t is the resistance of the test lead connected to the LO pin, and r is the resistance of the device-internal wiring for the LO pin (up to 30 m Ω).

For two-wire resistance measurement, (measured current) \times ($R_t + r$)/1 μ V (count) is added to the resistance measurement error in only the 50 Ω range for 2W Ω , and (measured current) \times ($R_t + r$)/10 μ V (count) is added in other ranges that include Lo- Ω . Here, *count* is the minimum resolution in the resistance range.

In addition, for measurement using the Dual FUNCTION combination 4W Ω and DCA, there is no error addition if the measured current is stable, but, if DCA constantly changes, the measured value changes within the specified error range.

Note that the polarity of the voltage (or resistance) measurement error is reversed if the measured current is DCA.

If there is little change in the measured current, the REL calculation for the voltage (or resistance) function is effective.

If the measured current is ACA, the error is determined by the rejection performance (NMRR).

Therefore, for a FAST sample that does not have rejection or a measured signal other than that of the power supply frequency, measurement is not stable and the accuracy is not guaranteed.

Measurement Methods

- 4) When using Dual FUNCTION to measure the alternating voltage and current by using the V (or Ω) pin, mA or 10A pin, and LO pin as input pins, interference affects the accuracy of alternating current and direct current measurements.

Assuming that ACV (or (DC+AC)V) is a sine wave, Hz is the frequency, and V is the effective voltage value:

- ① For ACA (or (DC+AC)V), an error of $\text{Hz} \times V/100 \pm 500$ (count) is added.

Here, *count* is the minimum resolution in the ACA range. Note that, if there is only a connection and no Dual FUNCTION operation, the error is $\text{Hz} \times V/100$ (count).

- ② For DCA, an error of ± 20 (count) is added for frequencies up to 1 kHz. The effects of ACV measurement on DCA at frequencies over 1 kHz are not guaranteed.

- 5) For the Dual FUNCTION combination DCV and $^{\circ}\text{C}$, the thermocouple electromotive force measured by DCV and the temperature measured by $^{\circ}\text{C}$ are simultaneously displayed, and the measured target is the same for both.

For the VOAC7520H/7523H combination CH-B DCV and $^{\circ}\text{C}$, it is possible to simultaneously measure the DCV and temperature for different locations.

- 6) If using the Dual FUNCTION combination $2\text{W}\Omega$ and $4\text{W}\Omega$ for the VOAC7521H/7522H, the measured resistance is the same for both. It is possible to compare the effects of test lead wiring and contact resistance.

- 7) The internal relay switches during Dual FUNCTION operation. If using Dual FUNCTION for a long time, be careful not to shorten the interval more than necessary. Note that the relay is a consumable and that replacing it must be paid for. The approximate life of the relay is as follows.

If the relay has an expected life of 10 million switches when used in the ideal range and the interval is one second:

- If the product is used eight hours a day, 20 days a month: Approximately 17 months
- If the product is used continuously: Approximately four months

However, the relay does not operate for the following combinations:

DCV and DCA, DCV and ACA, CH-B DCV and DCV, CH-B DCV and DCA, CH-B DCV and ACA, or CH-B DCV and $^{\circ}\text{C}$

(CH-B DCV is only installed in the VOAC7520H/7523H.)

4.3.3 Dual function selection menu

Because this menu is used to specify the measurement functions used during Dual FUNCTION operation, it is possible to constantly check which functions are selected and whether the combination can be specified while working. (Functions can be specified in the same way as during Single FUNCTION operation.)

The Dual FUNCTION selection menu is not used to perform measurement. Instead, this menu constantly displays which functions are assigned as the main and sub functions, as shown below.

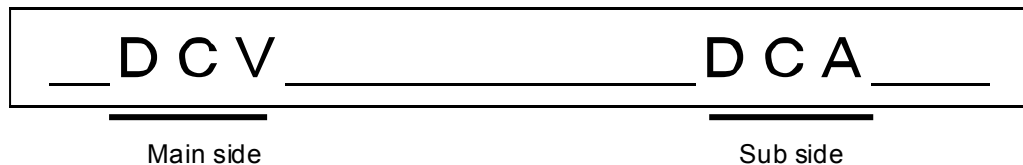



In addition, if functions that cannot be combined are specified, the combination error "<NG>" is displayed. The following shows an example of a combination error due to the same function being assigned twice.

(While there is a combination error, it is not possible to confirm the selected functions and return to the measurement processing.)

















Operating procedure

Opening the menu

- ① It is confirmed that Dual FUNCTION is measured. It is not possible to enter this menu while measuring Single FUNCTION.
- ② Press the  key to make it blink.
- ③ Press the  (FUNC SEL) key to light up the  key and open the Dual FUNCTION selection menu.

Selecting functions





- ① Press the  key (or  key) to select whether to make the current function the main function or sub function.
- ② As during Single FUNCTION operation, use each function key (       ) and the  key to select measurement functions. (The  and  keys can also be used for selection.)
- ③ Press the  key to confirm the selection and return to the measurement processing. Press the  key to discard the selection (reverting to the original function) and return to the measurement processing.

Measurement Methods

4.3.4 Performing calculations using the main and sub Dual FUNCTION

During Dual FUNCTION operation, it is possible to perform arithmetic calculations on the values displayed on the main-function and sub-function sides and then display the result on the sub-function side.

Operating procedure

- ① Press the  key to make it blink.
- ② Press the  key. ChCALC=OFF is displayed.
- ③ Press the  or  key to select Main*Sub, Main/Sub, Main+Sub, or Main-Sub.
- ④ Press the  (ENTER) key to confirm the setting.

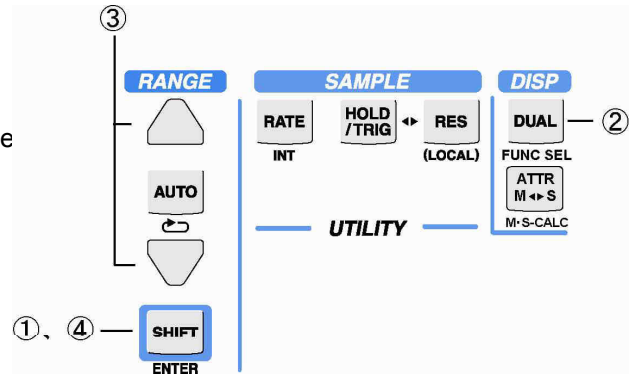

CAUTION!!

The results of Dual FUNCTION calculations can only be displayed. These results cannot be saved or output to a remote location. (However, the normal measurement results obtained using the sub function can be saved or output to a remote location.)

Dual FUNCTION calculations use the results of scaling, decibel, and relative value calculations performed for each function.

If the main or sub function has any of the following statuses, the result of performing a Dual FUNCTION calculation has the same status:

- Measurement value overload
- The number of samples for moving average calculations has not been reached.
- Scaling calculation overflow
- Log (0) error in a decibel calculation

4.4 Displayed Information

The display and LEDs indicate measurement results and attribute information, but the displayed information differs depending on the operating status. In particular, the following major differences exist between Single FUNCTION operation and Dual FUNCTION operation. (For details about the displayed information, see the next and following sections.)

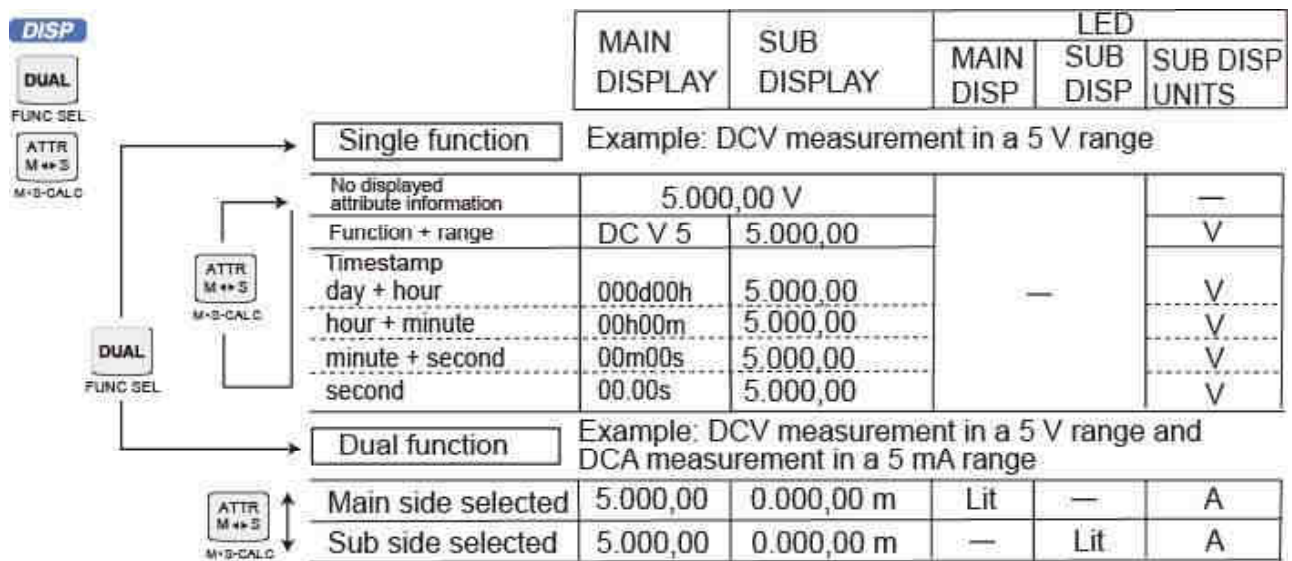

Measurement Methods

4.4.1 Information displayed during Single FUNCTION measurement

During Single FUNCTION measurement, the following information is displayed.

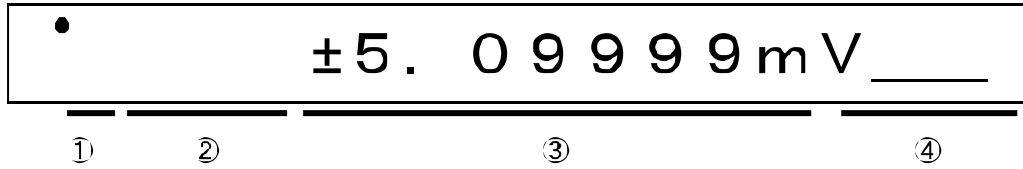

① Sampling indicator

② Comparator calculation result or type of statistical information

The information displayed in this area is determined by the calculation settings as shown in the following table.

		Comparator Calculations	
Statistical Calculation Mode	Displayed Data Type	OFF	ON
OFF	—	“_____” (not displayed)	* Comparator calculation result
CONT, SINGLE, REPEAT	Raw data	“_____” (not displayed)	* Comparator calculation result
	Max data	“M a x”	“M a x”
	Min data	“M i n”	“M i n”
	Min data	“A v g”	“A v g”
	Min data	“_σ_”	“_σ_”

* For details about the displayed comparator calculation result, see the “Comparator calculation” section.

③ Measurement result (including the sign and multiplier)

④ Unit

4.4.2 Attribute information displayed during Single FUNCTION measurement

During Single FUNCTION measurement, it is possible to display attribute information in addition to measured values.

The displayed items and formats are as follows.

Displayed Attribute Item	Display Example
No displayed attributes (normal display)	±50.9999mV
Function and range	DCV 50m±50.9999m
Timestamp: Day and hour	012d23h±50.9999m
Timestamp: Hour and minute	23h59m±50.9999m
Timestamp: Minute and second	59m59s±50.9999m
Timestamp: Millisecond	59.99s±50.9999m

While attribute information is displayed, the units can be determined by using the “SUB DISP UNITS” LEDs. Whether these LEDs are lit is the same as for Dual FUNCTION operation.

Operating procedure



Each time the  key is pressed, the displayed attribute item is switched in the following order: Normal display, function and range, day and hour, hour and minute, minute and second, millisecond, normal display...

Measurement Methods

4.4.3 Information displayed during Dual FUNCTION measurement

During Dual FUNCTION measurement, the following information is displayed.

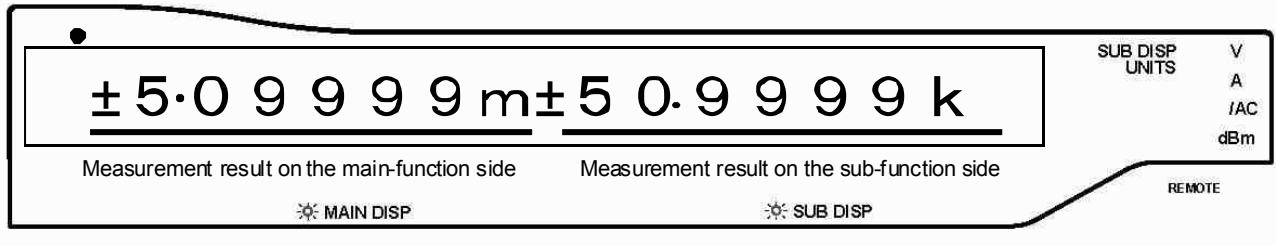

Unlike during Single FUNCTION measurement, it is not possible to display comparator calculation results and attribute information other than measurement results. In addition, the units are not displayed. However, the units can be determined by using the SUB DISP UNITS LEDs.

SUB DISP UNITS

When Dual FUNCTION operation is switched to, the SUB DISP UNITS LEDs on the right side of the display indicate the units of the sub function. The following table shows which LEDs are lit.

Function	Decibel Calculation Status	SUB DISP UNITS LEDs			
		V	A	Ω / AC	dBm
DCV / CH-B DCV	OFF	●	○	○	○
	dBm	○	○	○	●
	dBV	●	○	○	●
ACV / (DC+AC) V	OFF	●	○	●	○
	dBm	○	○	●	●
	dBV	●	○	●	●
2W Ω / 4W Ω / LowPower2W Ω	Always OFF	○	○	●	○
DCA		○	■	○	○
ACA / (DC+AC)A		○	●	●	○
TEMP (temperature measurement)		○	○	○	○
FREQ		○	○	●	○
DIODE		●	○	○	○

●: Lit ○: Off

Note: CH-B DCV is only available for the VOAC7520H/7523H. 4W Ω is only available for the VOAC7521H/7522H.

4.4.4 Exceptions displayed for measured values

The following table shows messages displayed when events occur during measurement and various other calculations.

Cause	Single FUNCTION Display	Dual FUNCTION Display
Measurement value overload	*1 ±00. 0000mV	*1 ±00. 0000m
Moving average calculation (number of samples not reached)	A V G . . .	A V G . . .
Statistical calculation (number of samples not reached)	N o D a t a	N o D a t a
Limit over	*2 ! L i m i t O v	*2 ! L i m i t
Scaling calculation overflow	! O v e r f l w	! O v r f l w
Decibel calculation Log(0) error	! L o g (0)	! L o g (0)

*1: Areas other than the sign, decimal point, and multiplier for the measured value are replaced with “0”.

*2: This indicates that the maximum range for voltage or current measurement has been overloaded.

4.5 Setting and changing sampling (SAMPLE)

4.5.1 Setting the sample rate (RATE)

The sample rate is the measurement cycle. Three levels can be selected: SLOW, MID and FAST. Stipulation of the sample rate differs according to the function. In addition, the measurement resolution may vary according to the sample rate. The sample rate setting is shared by all functions.

Operating procedure

Setting the sample rate

- By pressing the  key during a measurement, the sample rate changes from SLOW to MID to FAST (then back to SLOW).





When changing the sample rate, the sample rate setting is temporarily displayed.

4.5.2 Setting the measurement interval (INT)

Measurement intervals can be measured over long cycles of one second or longer. INT is used when saving lengthy logging data to the multimeter.

Operating procedure

Setting the measurement interval

- Press the  key so that it flashes.
- Press the  (INT) key.
- Use the ,  and  range keys to specify the measurement interval.

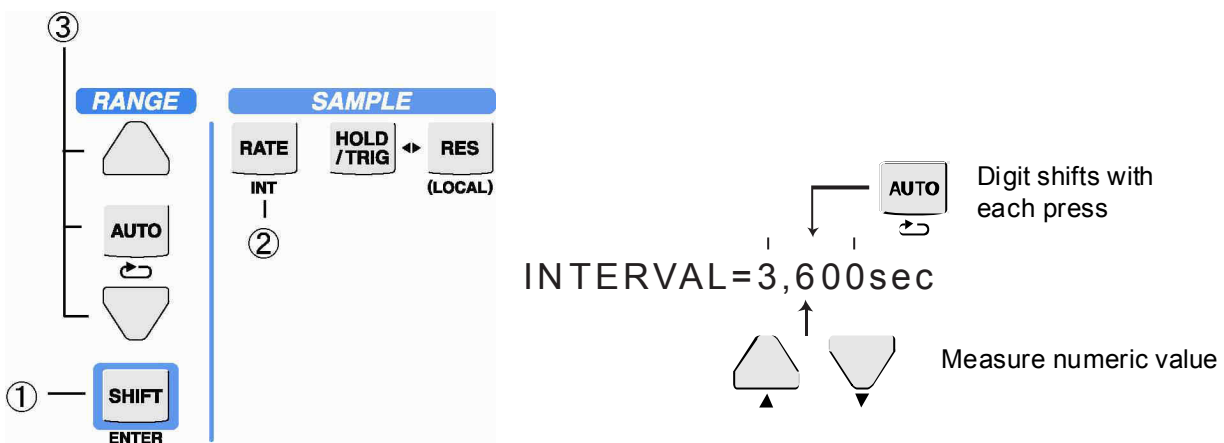

CAUTION!

The measurement resolution is not related to the setting of the interval time. It depends on the sample rate setting. When the standard measurement cycle for Dual FUNCTION operations and slow frequency measurements, etc., is longer than the cycle specified by the interval time, the interval time will be disregarded.

4.5.3 Switching between free run and hold (HOLD/TRIG and RES)

A free run operation is an operation in which measurements are repeatedly performed at cycles set according to the sampling rate and interval time. On the other hand, a hold operation is an operation in which the multimeter initiates a measurement when it receives a trigger.

Changes in the free run/hold status during a measurement

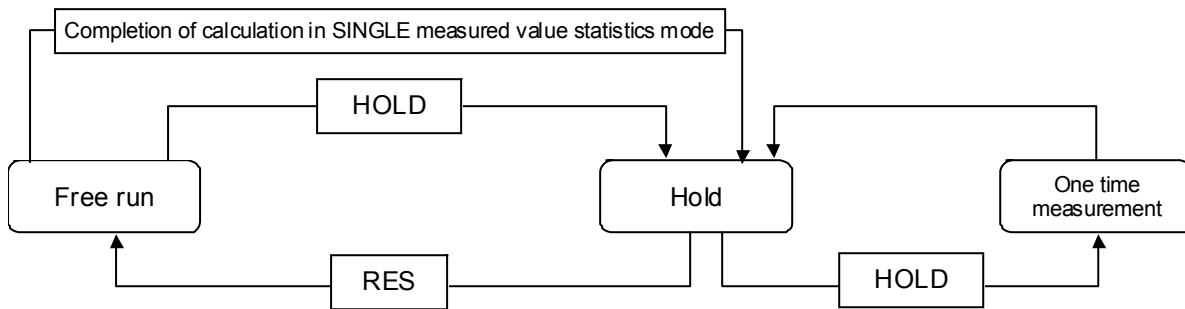

*When the AVG calculation is on, n measurements will be taken. The HOLD key will turn off during the measurements.

Trigger

A trigger is an event that initiates a measurement during a hold operation. There are three causes of triggers, as shown below.

Trigger cause	Operation
Manual trigger	 (TRIG) key is pressed during a hold operation
Remote trigger	In remote mode, the address command is GET (GPIB only), while the remote command is * TRG or :MEAS?
External trigger	A signal is applied from the TRIG terminal of the DIO unit (optional)

All triggers are disregarded during a free run operation. Triggers are also disregarded during a hold operation until the previously triggered measurement has been completed. A trigger can be accepted when the  (TRIG) key is on.

4.6 Calculation functions (UTILITY)

The calculation utilities are shown in the table below.

Utility	Function
Continuity test	Implements continuity tests for the resistance measurement function
Moving average	Implements smoothing by calculating the moving average
Scaling	Implements scaling calculations
Decibel	Implements dBm and dBV calculations for voltage measurement function
Relative value	Implements a relative calculation of reference values
Comparator	Makes a comparison to the threshold value and divides the results
Statistics	Calculates MAX, MIN, average and SD for a measurement value

4.6.1 Processing flow

The calculation utilities process measurement results as shown in the flowchart below. Since they are independent, each calculation can be simultaneously set. Each calculation process reflects the results of previously executed calculations.

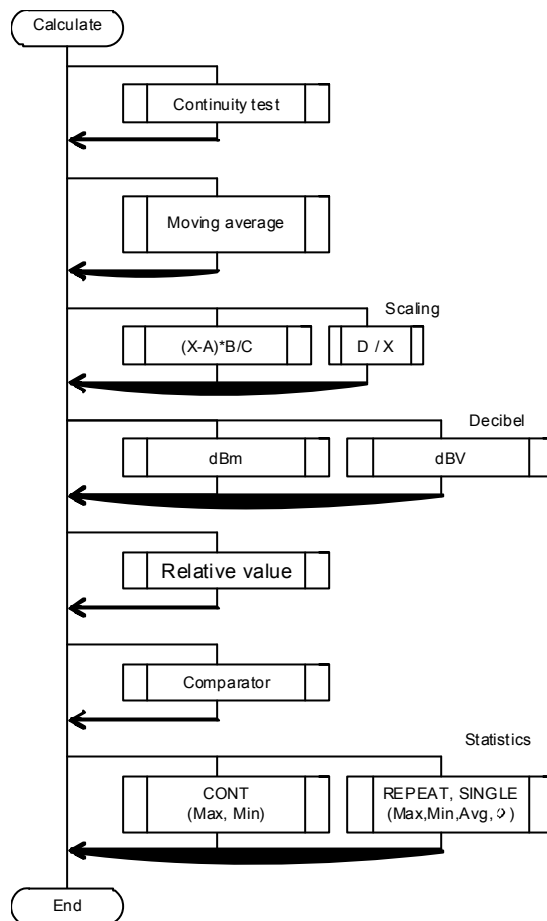

4.6.2 Table of utility parameters

This section describes details and setting ranges that can be set in shift mode.

Reference value in relative value calculations (REL)

Parameter	Details	Setting range
REF	Reference value	Arbitrary value (※)

Averaging frequency in moving average calculations (AVG)

Parameter	Details	Setting range
AVGCOUNT	Averaging frequency	2 to 255

Statistics calculation parameters (MAX/MIN)

Parameter	Details	Setting range
MOD	Operating mode for statistics calculations	OFF, CONT, REPEAT, SINGLE
SMPL	Repeat and Single sample number	2 to 255

Scaling calculation parameter (SCLE)

Parameter	Details	Setting range
MOD	Scaling calculation mode	(X-A)*B/C, D/X
A	A in (X-A)*B/C	Arbitrary value (※)
B	B in (X-A)*B/C	Arbitrary value (※)
C	C in (X-A)*B/C	Arbitrary value (※)
D	D in D/X	Arbitrary value (※)

Comparative values in comparator calculations (COMP)

Parameter	Details	Setting range
▲▲	RED upper limit	Arbitrary value (※)
▼▼	RED lower limit	Arbitrary value (※)
▲	YELLOW upper limit	Arbitrary value (※)
▼	YELLOW lower limit	Arbitrary value (※)

Diode measurement current (If)

Parameter	Details	Setting range
If	Measurement current	10 mA, 1 mA

Thermocouple type setting (TC)

Parameter	Details	Setting range
TCType	TCType	R, K (CA), T (CC), J (IC), E (CRC)

Measurement Methods

Decibel calculation parameters (dBV, dBm)

Parameter	Details	Setting range
MOD	Decibel calculation mode	dBm, dBV
dBm-Ref	Reference resistance value in dBm calculations	4, 8, 16, 32, 50, 75, 93, 110, 125, 135, 150, 200, 250, 300, 500, 600, 800, 900, 1000, 1200, 8000
dBV-Ref	Reference voltage in dBV calculations	1.0 μ V, 1.0mV, 1.0V

Interval time (INT)

Parameter	details	Setting range
INT	Interval time	0 to 3, 600sec (However, 0 sec is free run)

Continuity test threshold resistance (Rth)

Parameter	Details	Setting range
R-THRSLD	Threshold resistance	1.0 to 5, 000.0 Ω (0.1 Ω increments)

Calculation configuration between Dual FUNCTION (STYLE)

Parameter	Details	Setting range
ChCALC	Calculation mode between Dual FUNCTION	OFF, "Main*Sub", "Main/Sub", "Main+Sub", "Main-Sub"

✳️Configuring arbitrary value parameters



The arbitrary values used in parameters for relative value calculations, scaling calculations and comparator calculation are as follows.

- Display format

\pm 9 9 9 . 9 9 9 k
 | | |
 Sign Mantissa Exponent



Sign: positive or negative
 Mantissa: Numeric value consisting of 6 valid digits
 Exponent: Exponent of 10 (determined by the multiplier and decimal place position)

- Sign

The sign can either be + or -. Align the cursor with the sign using the  key and use the  and  keys to change the sign. Note that when the mantissa is 0, the sign is fixed to +.

- Mantissa



The valid number of digits in the mantissa is six. Exponents of 10 are displayed as K (10^3) and M (10^6). Place

the cursor next to the digit you want to change using the  key and then press the  and  keys to increase/decrease the value of the digit by one. Digits can be increased or decreased as needed. However, if the permissible range (excluding the decimal point), 000000 to 999999, is exceeded as a result of increasing/decreasing the numeric value, the key operation will be disregarded.



• Exponent

The exponent part is represented by exponents of 10. The exponent is expressed by the position of the

decimal point and multiplier. Align the cursor with the exponent (multiplier) using the  key. Press the

 and  keys to change the decimal point position and the multiplier such that the value increases by 10 times or decreases by 1/10.

Example of changing the exponent:

		Value	Display
Original value	→	9.99999E5	999.999k
Press 	→	9.99999E6	9.99999M
Press 	→	9.99999E4	99.9999k

Measurement Methods

4.6.3 Continuity tests

When performing a continuity test during a $2W\Omega$, $4W\Omega$ or $Lo-\Omega$ measurement (VOAC7521H / 7522H only for $4W\Omega$), the resistance value can be simultaneously measured. When a circuit shorts, the internal electronic buzzer intermittently sounds. When a disconnection occurs, the buzzer does not sound, enabling the circuit continuity to be confirmed.

Continuity is evaluated according to the condition that measurement value is less than the threshold value, based on the user setting for threshold value (Rth).

The on/off state of the continuity test and the threshold value are set and maintained for each measurement function.

Connection method

Refer to the precautions related to connecting the test leads in 4.1.1

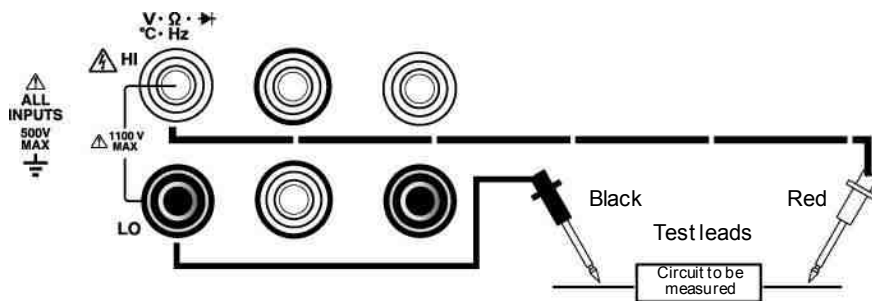

$2W\Omega$ and $2W\Omega$ (Low Power) example

- Connect the black measuring lead to the LO terminal and to one side of the circuit being measured.
- Connect the red lead to the $V \cdot \Omega \cdot C \cdot Hz$ terminal and to the other side of the circuit being measured.



Operating procedure

ON/OFF of continuity tests

- ① Press the $2W\Omega$ $Lo-\Omega$ key or the $4W\Omega$ $\rightarrow (Ir)$ key to make a selection.
- ② Press the ∇ and \blacktriangledown keys or the **AUTO** key to select the optimum range.
- ③ Press the Ω $\equiv ||$ key to turn the continuity test on and press it again to turn it off.

Setting the threshold resistance value



- ① Press the **SHIFT** **ENTER** key and it will flash.
- ② Press the Ω $\equiv ||$ (Rth) key. The menu for setting the threshold resistance value shown below will be displayed.

③ Set the threshold value (Rth) using the ,  and  range keys. The setting range is from 1.0 to 5000.0 Ω and changes in 0.1 Ω intervals.

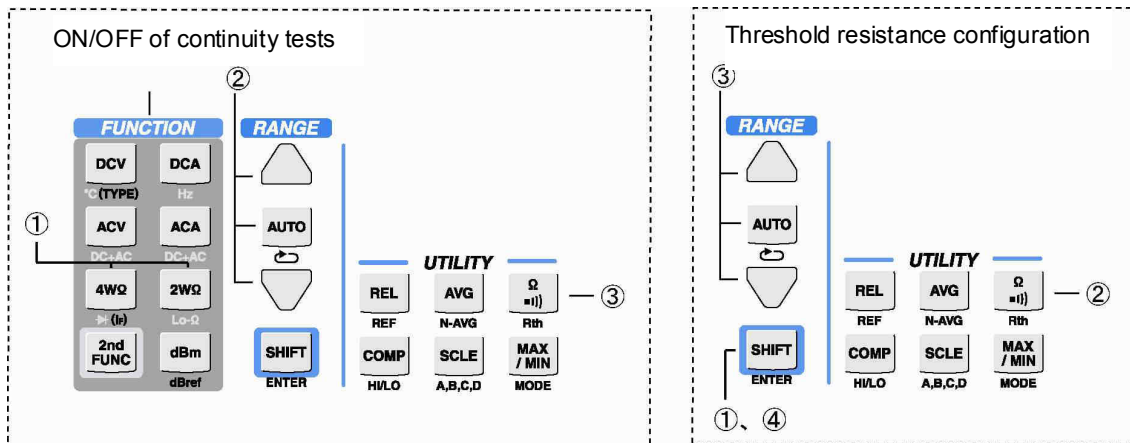
④ Press the  (ENTER) key to confirm the setting.



Threshold resistance configuration

1	R-THRSLD=0,010.0 Ω	Leftmost digit flashes
2	Press  key.	Set
3	Press  and  key.	Set resistance
	R-THRSLD=0,110.0 Ω	
4	Set the remaining digits using the same method	

CAUTION!!

During a Dual FUNCTION operation, the continuity test compulsorily switches off.

When the continuity test is switched from off to on, the following changes are automatically carried out.

- The sampling rate changes to FAST. (MID for 5M Ω ~500M Ω)
- The interval time setting is disregarded.

These changes are restored when the continuity test is switched off again.

Measurement Methods

4.6.4 Moving average calculation (AVG)

Smoothing processing is carried out by the moving average calculation. It is used when there are significant variations in measurement values. The on/off state of the moving average calculation and the averaging frequency are set and maintained for each measurement function.

Operating procedure

Switching the calculation on and off

① Specify the measurement function.

② Press the  and  keys or the  key to select the optimum range.

③ Press the  key. The key will flash and the AVG calculation will be turned on. Press the key again to turn the calculation off.



- Once the AVG calculation has been switched on, "AVG..." will be displayed until the initial measurement result has been obtained.

Setting the averaging frequency

① Specify the measurement function.

② Press the  key and it will flash.

③ Press the  (N-AVG) key. "AVGCOUNT=XXXSMPL" will appear.

④ Set the averaging frequency (3 digits) of the AVG calculation using the ,  and  keys.

⑤ Press the  (ENTER) key to confirm the setting.

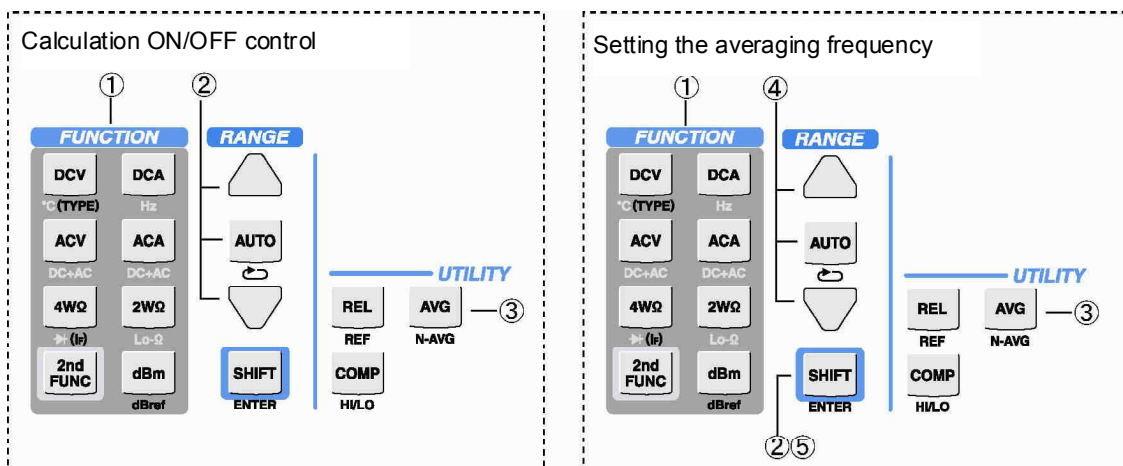

CAUTION!!

The moving average calculation is reset in the following situations:

- Sample rate change
- Hold ↔ free run change
- Single FUNCTION operation ↔ Dual FUNCTION operation change
- Measurement function change
- Measurement range change (including auto range)

RES

- When the (LOCAL) key is pressed during a free run operation
- Moving average calculation is switched off/on
- Reset from shift mode
- Measurement value overload

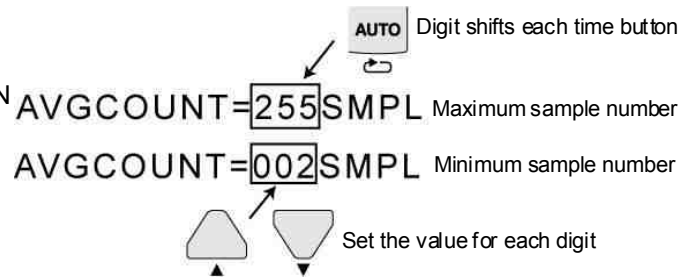

Measurement Methods

4.6.5 Scaling calculation (SCLE)

This function carries out the calculation, $(X-A)*B/C$ or D/X , using the measurement value, X, and the constants, A, B, C and D, preset by the user. It is used to convert units, such as $V \Rightarrow A$ and $Hz \Rightarrow RPM$.

The on/off state of the scaling calculation, mode (arithmetic expression) and the constants are set and maintained for each measurement function.

Operating procedure

Setting the calculation on and off

- Specify the measurement function.



- Press the **A,B,C,D** key to turn the scaling calculation on. Press it again to turn it off.

Setting mode (arithmetic expression) and constants

- Specify the measurement function.



- Press the **ENTER** key and it will flash.



- Press the **A,B,C,D** (A,B,C,D) key. "SCL: MOD= (X-A) *B/C" will appear on the display.

- Set the mode and the constants, A, B, C and D, using the , and keys.



- Press the **ENTER** (Enter) key to confirm the settings.



- Press the **A,B,C,D** key to display the calculation results.

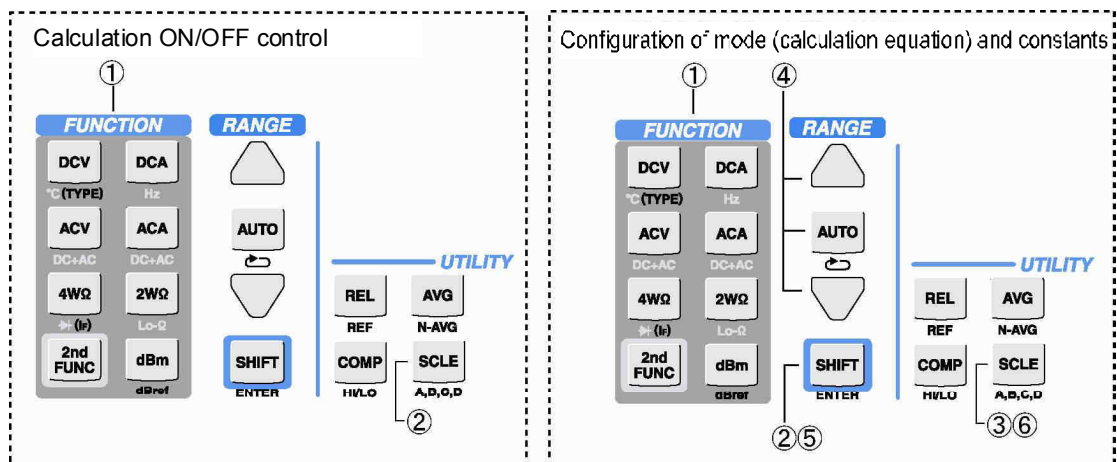



CAUTION!

If the number of valid digits in a measurement result is less than six, the calculation will be carried out assuming the underflow to be 0. The scaling calculation will over flow under the following conditions.





- Division by 0
- The absolute value of the calculation result exceeds 999.999T

If the above occur, the word "!"Ovrflw" will be displayed. In the event of a measurement value overload, the scaling calculation will not be executed.

Configuration of the calculation equation

1	$SCLMOD=(X-A)*B/C$	MOD flashes
2	 Press [AUTO]	(X-A)*B/C flashes
3	 Press [UP and DOWN]	
4	$SCLMOD=D/X$	D/X flashes

Configuration of constants

5	 Press [AUTO] $SCLMOD=(X-A)*B/C$	MOD flashes
6	 Press [UP and DOWN] $SCLA=+0.000,00p$	Display constants A, B, C and D
7	 Press [AUTO]	Number flashes
8	$SCLA=+0.000,00p$  Press [UP and DOWN]	Configure number
9	Configure each digit and unit using the same	

Measurement Methods

4.6.6 Decibel calculations

The decibel calculation performs decibel conversion of measurement values for the DCV, ACV, (DC+AC) V and CH-B DCV measurement functions.

The dBm calculation performs a decibel calculation of the power consumption of resistance referenced to 1 mW from the measured voltage.

The dBV calculation performs a decibel calculation of the ratio between the measurement voltage and the reference voltage.

The on/off state of the decibel calculation, and the calculation mode (dBm/dBV) and reference resistance/voltage are set and maintained for each measurement function.

Equations:

$$dBm = 10 \times \log_{10} \left(\frac{\text{Measured value}^2 / \text{Reference resistance}}{1.0 \times 10^{-3} [W]} \right)$$

Here, the following values can be selected as the reference resistance:

4, 8, 16, 32, 50, 75, 93, 110, 125, 135, 150, 200, 250, 300, 500, 600, 800, 900, 1000, 1200 and 8000 Ω

$$dBV = 20 \times \log_{10} \frac{|\text{Measured value}|}{\text{Reference voltage} [V]}$$

Here, the following values can be selected as the reference voltage:

1.0 μ V, 1.0mV and 1.0V

Relative value dB

By combining the decibel calculation with a relative value calculation, the decibels of the ratio to the reference value can be calculated as follows. (Also refer to the explanation on relative value calculations.)

$$\begin{aligned} REL \ \& \ dBV &= dBV \ (\text{Measured value}) - dBV \ (\text{REF value}) \\ &= 20 \times \log_{10} \frac{|\text{Measured value}|}{\text{Reference voltage}} - 20 \times \log_{10} \frac{|\text{REF value}|}{\text{Reference voltage}} \\ &= 20 \times \log_{10} \frac{|\text{Measured value}|}{|\text{REF value}|} \end{aligned}$$

Operating procedure

Switching the calculation on and off

- ① Set the measurement function to voltage measurement.

- ② Press the  key to turn the decibel calculation on and press it again to turn the calculation off.

Setting the mode (dBm/dBV) and reference value

- ③ Press the  key and it will flash.

- ④ Press the  (dBref) key.

Refer to operating procedures in 4.2.9, dB measurements.

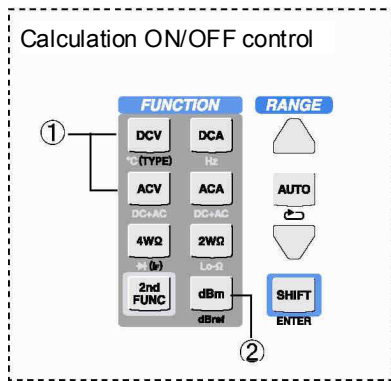

(VOAC7521H/7522H)

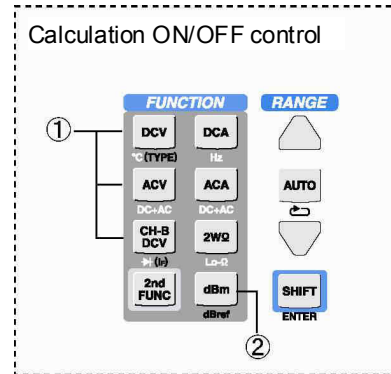

(VOAC7520H/7523H)

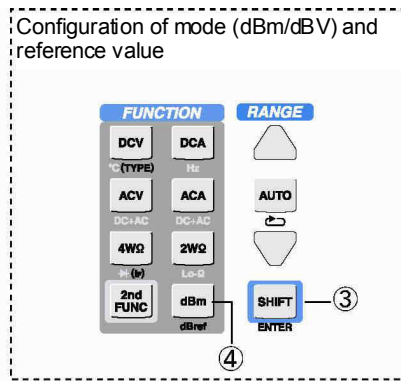

(VOAC7520H/7523H)

CAUTION!!

If the measurement value for the decibel calculation is 0, a LOG (0) error will be generated. The message, "Log (0)" will be displayed when this occurs.

If there is an overload in the measurement value, or an overflow in the results of the scaling calculation, the decibel calculation will not be executed.

4.6.7 Relative value calculation (REL)

REL calculates the comparative value with regard to the reference measurement value. The equation is "Output = measurement value – REF value." This calculation is useful when wanting to take measurements that eliminate measuring lead resistance during 2 WΩ measurements or the external thermo electromotive force of DC micro voltages. REL also makes it possible to measure deviations from the reference value. The on/off state of the relative value calculation and reference values are set and maintained for each measurement function.

Operating procedure

Switching the calculation on and off (integrating the measurement value as a reference value)

① Specify the measurement function.

② Press the  and  keys or the  key to select the optimum range.

③ Press the  key to turn the relative value calculation on. Press it again to turn the calculation off.

④ When the calculation is switched from off to on, the measured value immediately following will be integrated as the reference value. As a result, the value displayed immediately after switching the calculation on will be 0.



⑤ The reference value can also be incorporated by pressing the  key during a free run operation with the relative value calculation on.

Manually setting the reference value when the calculation is off

① Select the measurement function.

② Press the  key so that it flashes.

③ Press the  (REL) key. The reference value configuration menu below will be displayed.

④ Set the reference value using the ,  and  range keys.

⑤ Press the  (ENTER) key to confirm the setting.

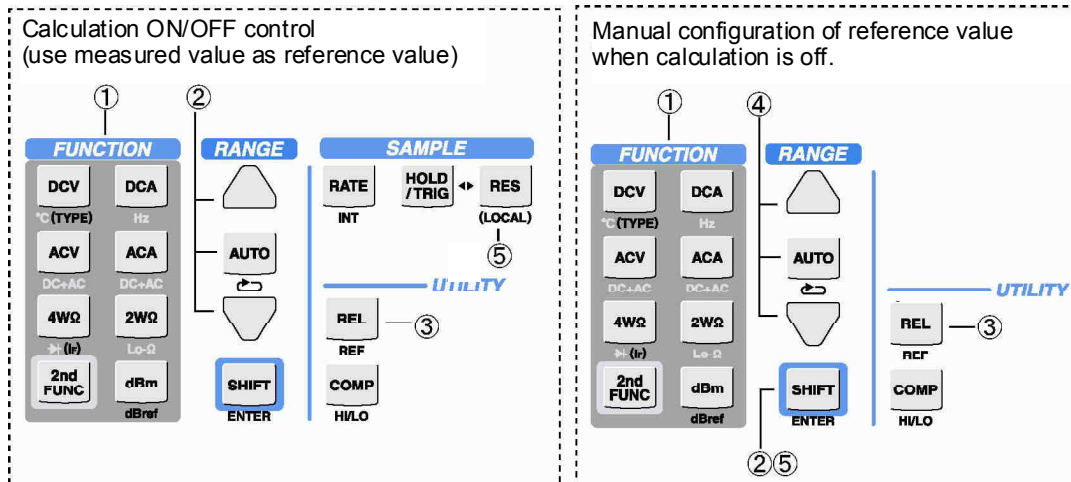

CAUTION!!

Even if the reference value is manually set when the relative value calculation is off, it will automatically be cleared when the relative value calculation is switched on. Erroneous data is handled as shown in the table below.

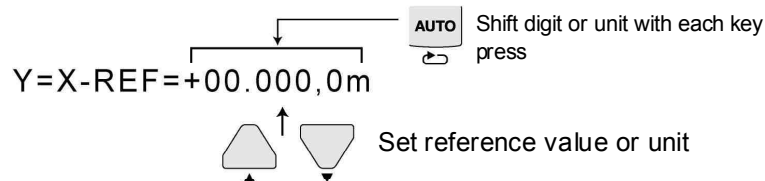

Y: displayed value (differential) X: measured value REF: reference value

Measurement value	Scaling calculation	Decibel calculation	Relative value calculation output
Normal	Normal	Normal	Output the relative value calculation result
Normal	Normal	Log (0) error	Log (0) error
Normal	Overflow	All conditions	Overflow
Overload	All conditions	All conditions	Overload

Measurement Methods

4.6.8 Comparator calculation (COMP)

COMP makes a comparison between the measurement value and two-step upper and lower comparative values previously set by the user and classifies them into five zones.

The on/off state of the comparator calculation and the comparative value are set and maintained for each measurement function.

Operating procedure

Two-step comparator calculations

Comparator calculations involve a RED ($\blacktriangle/\blacktriangledown$) and YELLOW ($\blacktriangle/\blacktriangledown$) two-step comparison. RED level evaluation is implemented first. The YELLOW level evaluation is only implemented when the “measurement value < RED upper limit” and the “measurement value > RED lower limit.” If the upper/lower limit of either level is set to $\pm 999.999T$ (initial value), the evaluation of that level always becomes Go. When two-step evaluation is unnecessary, use this setting.

The “Hi/Go/Lo” evaluation results of each level and their relationships with the final calculation results are shown in the following table.

RED level comparison result	YELLOW level Comparison result	Comparator calculation result	
Hi (measurement value > \blacktriangle)	Irrelevant	\blacktriangle	Red Hi
Go (measurement value < \blacktriangle and measurement value > \blacktriangledown)	Hi (measurement value > \blacktriangle)	\blacktriangle	Yellow Hi
	Go (measurement value < \blacktriangle and measurement value > \blacktriangledown)	\blacktriangle • \blacktriangledown	Go
	Lo (measurement value < \blacktriangledown)	\blacktriangledown	Yellow Lo
Lo (measurement value < \blacktriangledown)	Irrelevant	\blacktriangledown	Red Lo

Switching the calculation on and off

- 1 Select the measurement function.



- 2 Press the  key to turn the comparator calculation on. Press the key again to turn it off.

Setting the comparative value of the comparator calculation

- 1 Select the measurement function.



- 2 Press the  key and it will flash.



- 3 Press the  (HI/LO) key. The comparative value configuration menu below will be displayed.

- 4 Set the comparative value using the ,  and  range keys.



- 5 Press the  (ENTER) key to confirm the setting.

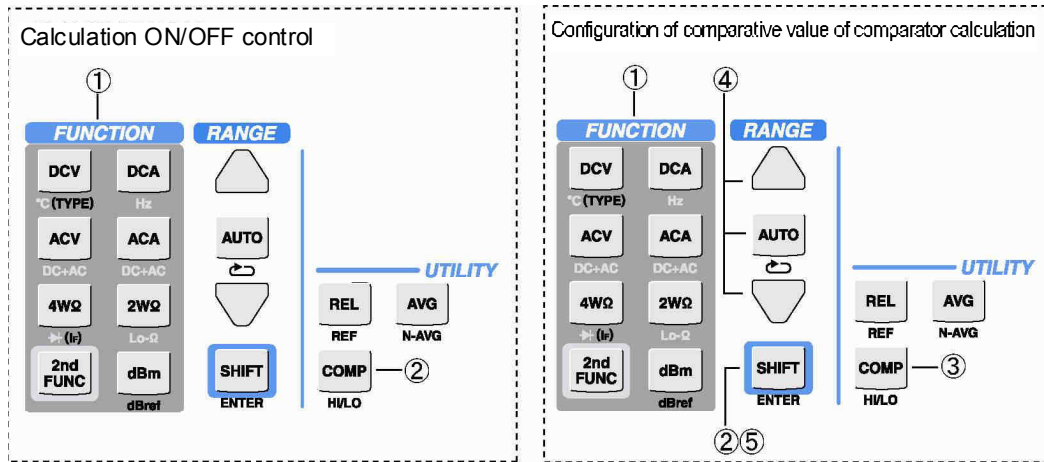

Configuration of comparative value

1	CMP: = +999.999T	RH flashes
2	Press [AUTO]	+ or - flashes
3	Press [UP/DOWN]	Specify + or -
4	Press [AUTO] CMP: = +9.99.999T	Leftmost digit flashes
5	Press [UP/DOWN] CMP: = +5.99.999T	Configure leftmost digit
6	Set the digits for , and and the units using the same method	



Output of comparator calculation result

The comparator calculation result is output by display, beep sound and DIO unit (option). The display output is as follows.

Evaluation result	Display
Red Hi	
Yellow Hi	
Go	
Yellow Lo	
Red Lo	

Measurement Methods

Beep sound

The condition under which the beep sounds is controlled by the following two system menu parameters:

“BEEP: COMP=GO/NOGO/OFF”

“CMP: LEVEL=RED/YELLOW”

The conditions under which the beep sounds are as follows. (The beep sounds when the condition is TRUE in the table below.)

	BEEP: COMP =	OFF	GO		NO GO	
	CMP: LEVEL=	* (Don't Care)	RED	YELLOW	RED	YELLOW
Calculation result	▲ Red Hi	FALSE	FALSE	FALSE	TRUE	TRUE
	▲ Yellow Hi		TRUE			
	• Go			TRUE	FALSE	FALSE
	▼ Yellow Lo			FALSE	TRUE	TRUE
	▼ Red Lo		FALSE	FALSE	TRUE	TRUE

For the DIO unit, see the section on “DIO option.”

CAUTION!

When the comparative value is set to “upper limit < lower limit,” an error occurs. When this occurs, a “!” will be displayed for the comparator calculation result.

The comparator calculation result screen will not be shown during a Dual FUNCTION operation. In addition, comparator calculations will not be executed for the following data:

- Overload in a measurement value
- Overflow in a scaling calculation
- Log (0) error in a decibel calculation result

4.6.9 Statistical calculations (MAX/MIN)

MAX/MIN obtains the maximum, minimum, average and standard deviation (σ) of measured values. A peak hold of the max and min values is done in continuous (CONT) mode. This function is useful when later recalling the max and min values of voltage changes after measuring the AC line power source voltage over a long period.

In repeat or single mode, max, min, average and standard deviation are calculated for the specified number of samples.

The statistical calculation mode and settings for the number of samples are set and maintained for each measurement function.

Operating procedure



Note: Other utilities and operations are different. During a measurement operation, the  key is used to select the displayed data type. The calculation is turned on and off by changing the statistical calculation mode in the shift menu.

Setting the calculation mode and number of samples

① Select the measurement function.

② Press the  key and it will flash.

③ Press the  (MODE) key. The mode/sample number configuration menu below will be displayed.

④ Set the mode and sample number using the ,  and  range keys.

⑤ Press the  (ENTER) key to confirm the setting.

⑥ Every time the  (MODE) key is pressed, Max, Min, Avg, σ or Raw (measured values) is displayed.

Measurement Methods

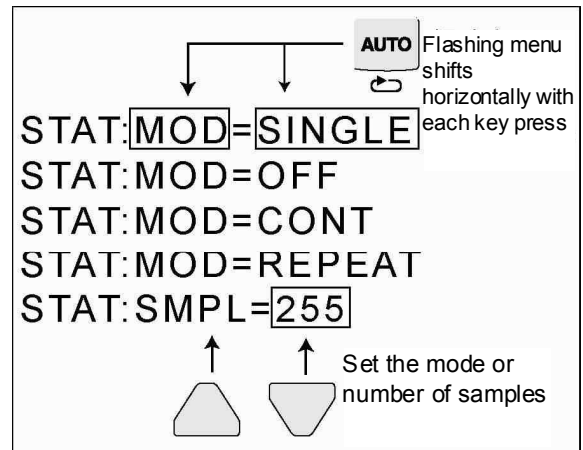
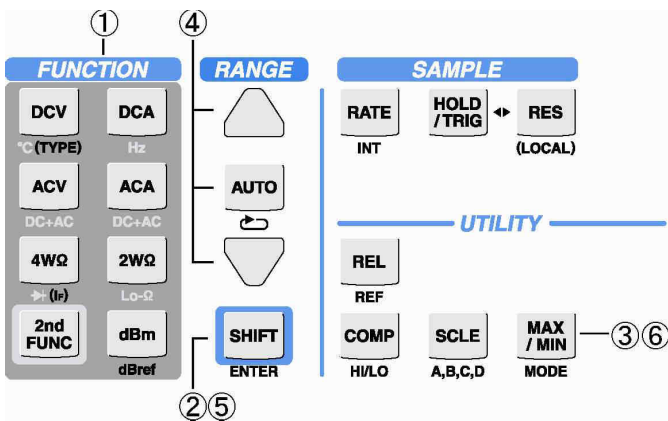

STAT: MODE: OFF

Turns the statistical calculation off

STAT: MODE: CONT (continuous mode)

Continuously performs max and min calculations. The results are updated for each measurement.



Pressing the **MODE** (MODE) key during a measurement operation in continuous mode changes the display data from MAX to MIN to RAW (then back to MAX) in sequence.

STAT: MODE: SINGLE/REPEAT (N single sample/repeat mode)

Max, min, average and standard deviation calculations are carried out for each specified sample number. The calculation results are updated at each specified sample number, N. Until N is reached, the previous calculation result is shown during the measurement operation. (Display data is excluded in the case of RAW.) "No Data" is displayed if there are no calculation results.



Pressing the **MODE** (MODE) key during a measurement operation in single/repeat mode changes the display data from Max to Min to Avg to σ to Raw in sequence.

In single mode, when the measurement results are updated after the sample number has reached N, the multimeter automatically shifts from a free run state to a hold state. In repeat mode, it maintains the free run state.

When taking a measurement while applying a trigger during a hold operation, the single mode and repeat mode operations are identical.

Standard deviation (σ) equation:

$$Average = \frac{\sum X_n}{N}$$
$$\sigma = \sqrt{\frac{\sum (X_n - Average)^2}{N}}$$

CAUTION!!

Statistical calculations are reset in the following situations:

- When switching between a Single FUNCTION operation and a Dual FUNCTION operation
- When changing the measurement function
- When changing the statistical calculation mode
- When changing the statistic sample number
- When the  (LOCAL) key is pressed during a free run operation

The following types of data are not included in samples for statistical calculations.

- Overload in a measurement value
- Overflow in a scaling calculation
- Log (0) error in a decibel calculation result

For statistical calculations made during a Dual FUNCTION operation, measurement function settings assigned by the main side are applied to the measurement function on the sub side.

In single/repeat mode for statistical calculations, the sampling rate is limited to 20 msec, even in Fast mode.









4.7 Saving and recalling setup (SETUP)

SETUP saves and recalls the panel setup. It also returns the panel setup to the factory settings by resetting them.

Operating procedure

Saving the setup

Saving the current panel setup to internal memory.

- ① Press the  key and it will flash and the  key will light up.
- ② Press the  key and select Save: # n [Shft].
- ③ Set the save memory number using the ,  and  range keys. (The setup can be saved in the range #1 to #10.)
- ④ Press the  (ENTER) key. Save? Y: ↓ N: ↑ will be displayed.
- ⑤ Press the  key to save the current setup in the specified memory. Press the  key to return to the original screen without saving the setup.

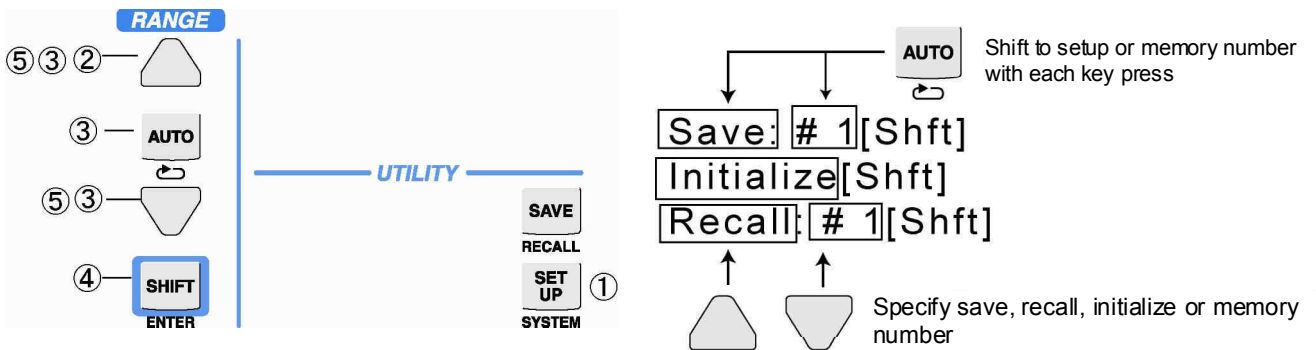

Recalling the setup

Recall is used to recall the current panel setup. The operating procedure is the same for the save operation.

Initializing the setup

This is used to reset the current panel setup to the factory settings. The operating procedure is the same for the save operation.

The details of changes that occur due to save, recall and reset operations for the setup are shown below.

System-related setup information (SYSTEM menu)

	Factory settings	Remote recall	Remarks
LOW-POWER=	60 min	○	—
Remotel/F=	None	×	—
RS: RATE=	9600 bps	×	—
RS: Parity=	None	×	—
RS: Stop-Bit=	1 bit	×	—
RS: Data-Lng=	8 bit	×	—
RS: Delim=	CR+LF	×	—
GPIB: Address=	9	×	Enabled when optional equipment attached
GPIB: Delim=	CR+LF	×	Enabled when optional equipment attached
GPIB: OIDCmd=	OFF	×	Enabled when optional equipment attached
IP: Address=	192.168.1.100	×	Enabled when optional equipment attached
IP: Subnet=	255.255.255.0	×	Enabled when optional equipment attached
IP: Gateway=	192.168.1.1	×	Enabled when optional equipment attached
IP: Port=	02000	×	—
IP: Delim=	CR+LF	×	—
BEEP: Key=	ON	○	—
BEEP: Caution=	ON	○	—
BEEP: Max/Min=	ON	○	—
BEEP: COMP=	NOGO	○	—
CMP: Src=	MAIN	○	—
CMP: Level=	RED	○	—
SAVE: Start=	#0000	○	—
SAVE: Count=	3000	○	—
SAVE: AdrInit=	ON	○	—
SAVE: TimInit=	OFF	○	—
Ω : VoltCheck=	ON	○	Exclusive measurement function for 2WΩ/4WΩ/LO-Ω/diode
Ω : AutoRng=	~500M	○	Exclusive measurement function for 2WΩ/4WΩ
DCVAutoRng=	50m~	○	Exclusive measurement function for DCV (VOAC7522H/VOAC7523H only)
AC(Slow)=	15Hz~	○	—
DIOTrig=	“-“	○	Enabled when optional equipment attached

Note: Items with an x in the “Remote recall” column are unaffected by the remote *RCL command.

Measurement Methods

Measurement-related setup information (common to all functions)

	Factory settings
Main side measurement function	DCV
Sub side measurement function	DCA
Dual FUNCTION	OFF (Single FUNCTION)
Sample mode	Free run
Sample rate	SLOW
INTERVAL=	0sec
ChCALC=	OFF
Display attribute information	OFF (display comparator calculation results/statistical data types)

Setup information independently maintained for each function

	Factory settings	Remarks
Range	AUTO range	—
Continuity test On/Off	OFF	2W Ω , 4W Ω & LowPower2W Ω only
Moving average calculation On/Off	OFF	
Scaling calculation On/Off	OFF	
Decibel calculation On/Off	OFF	DCV/CH-B DCV/ACV/ (DC+AC) V only
Relative value calculation On/Off	OFF	
Comparator calculation On/Off	OFF	
Statistical calculation On/Off	OFF	
X-REF=	+000.000k	—
AVGCOUNT=	010 SMPL	—
R-THRSLD=	0010.0 Ω	2W Ω , 4W Ω & LowPower2W Ω only
COMP: \blacktriangle =	+999.999T	—
COMP: \blacktriangledown =	-999.999T	—
COMP: \blacktriangle =	+999.999T	—
COMP: \blacktriangledown =	-999.999T	—
SCL: MOD=	(X-A)*B/C	—
SCL: A=	+000.000k	—
SCL: B=	+000.001k	—
SCL: C=	+000.001k	—
SCL: D=	+000.001k	—
STAT: MOD=	OFF	—
STAT: SMPL=	010	—
TC-Type=	K (CA)	Temperature measurement function only
If=	1mA	Diode measurement function only
dB: MOD=	dBm	DCV/CH-B DCV/ACV/ (DC+AC) V only
dB: dBm-REF=	600 Ω	DCV/CH-B DCV/ACV/ (DC+AC) V only
dB: dBV-REF=	1.0uV	DCV/CH-B DCV/ACV/ (DC+AC) V only

* CH-B DCV is only available on the VOAC7520H/7523H. 4W Ω is only available on the VOAC7521H/7522H.

Caution!



PowOn-Setup in the SYSTEM menu, which specifies whether to initialize the multimeter's panel setup immediately after power up, is not target to save, recall or initialize.

4.8 Saving and recalling measurement data (SAVE/RECALL)

Up to 3,000 measurement values can be stored in internal memory with a time stamp (elapsed time). This data can be recalled with the recall function and output to an external device by remote control. The stored data is maintained by battery back up and will not be lost when the power is switched off.

4.8.1 Saving measurement data (SAVE)







SAVE stores measurement values in the multimeter's internal memory. Configuration of SAVE operations is done via the SAVE menu in the SYSTEM menu. The SAVE parameters and their details are shown in the following table.

SAVE: Start=#0000	Sets the initial save address. The setting range is from 0 to 2,999.
SAVE: Count=0000	Sets the data count for data to be saved. The setting range is from 1 to 3,000.
SAVE: AdrInit=XXX	<p>Specifies an address operation when a save operation is complete.</p> <p>ON: returns a data storage address to the address specified in Start OFF: Sets the start address to the current write address</p> <p>AdrInit=ON is used when the user wants to save a large volume of continuous data, or when only the latest measurement result needs to be saved.</p> <p>AdrInit=OFF is used when repeatedly saving data while changing the measurement conditions. In this case, the initial write address is changed so as to avoid overwriting. Below is a graphical representation of the process of writing to memory when repeatedly saving data with AdrInit=OFF.</p>
SAVE: TimInit=XXX	<p>Specifies whether to reset the time stamp when commencing a save operation.</p> <p>ON: Resets the time stamp to "000d00h00m00.00s" when commencing a save operation. OFF: Does not do anything</p> <p>Note: When commencing a save operation, data that has been sampled is saved with the time stamp value prior to reset.</p>
SAVE: Clear: [AUTO]	<p>"Clear? Y: ▼ N: ▲" appears when the  key is pressed.</p> <p>Pressing the  key will delete all of the saved data.</p>



Measurement Methods

Operating procedure

Selecting the SAVE parameters

- ① Press the  key and it will flash.
- ② Press the  (SYSTEM) key. The SYSTEM menu will flash.
- ③ Press the  or  key. SAVE: XXX=xxx will be displayed.
- ④ Specify the save parameters described above using the ,  and  range keys.

SAVE execution

- ① Pressing the  key during a measurement will cause the multimeter to begin saving data. Measured data will continue to be saved until the save operation is complete. While data is being saved, the  key will remain switched on.

The data save operation will finish under the following conditions:

- When the stored data has reached the number of data specified in “SAVE: Count=xxx”
- When the  key is pressed again during the save operation
- When the remote “:SAVE:STAT OFF” command is received during the save operation
- When the shift mode is selected

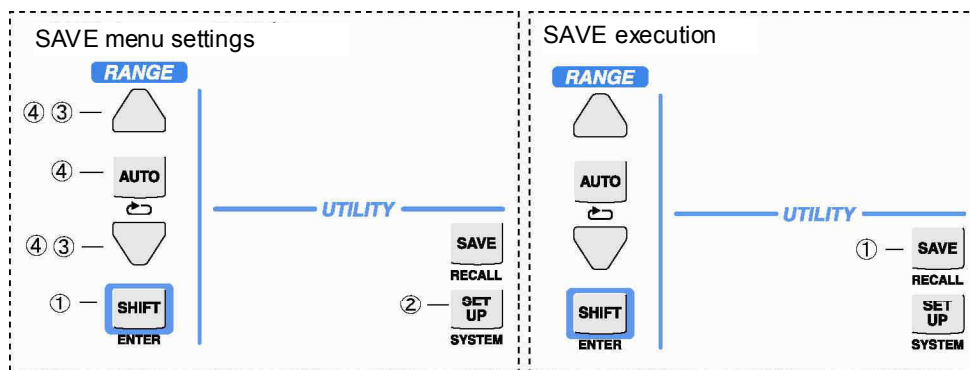

CAUTION!!

If the  key is pressed when the initial save address + number of stored data > 3,000, “Not Enough Mem...” will temporarily be displayed and the save operation will not begin. In this case, change either the initial address or the number of data.

4.8.2 Save formats for measurement data

Data saved by the SAVE function is saved in different formats according to the statistical calculation settings or the difference between Single FUNCTION and Dual FUNCTION. 1,500 pairs of data or less can be saved at Dual FUNCTION.

- 1) Single FUNCTION + statistical calculation mode = OFF or CONT
This format saves a single raw datum at each sampling.

- 2) Single FUNCTION operation + statistical calculation mode = REPEAT or SINGLE
Every time the statistical calculation sample number, N, is reached, the four data for the statistical calculation results (Max, Min, Avg and σ) are saved as a set. Raw data is not saved. All four of the statistical calculation results have the same time stamp.
The save sequence is Max, Min, Avg and σ .

- 3) Dual FUNCTION + statistical calculation mode = OFF or CONT
This format saves the two data for Main side measurement results and Sub side measurement results as a set. These two data both have the same time stamp.
The save sequence is Main and Sub.

- 4) Dual FUNCTION + statistical calculation mode = REPEAT or SINGLE
Every time the statistical calculation sample number, N, is reached, the four data for the statistical calculation results on the Main side and the Sub side are saved as a combined set of eight data. Raw data is not saved. All eight of the statistical calculation results have the same time stamp.
The save sequence is Max, Min, Avg and σ on the Main side, and then Max, Min, Avg and σ on the Sub side.

4.8.3 Recalling measurement data (RECALL)

Operating procedure

Switching between normal mode (measurement mode) and recall mode

- ① Press the  key and it will flash.

- ② Press the  (RECALL) key to enter the recall mode. The recall address will always be #0000.

- ③ Press the  key to exit from the recall mode.







Recall mode screen

In recall mode, specify the address (recall address) to display the measured value saved at that address. Specifying this address can simply be done by increasing/decreasing the current recall address by one, or by narrowing down the measurement conditions and jumping to the address. These two methods are used according to the following screens.

Measurement Methods

Screen	Application
Normal recall screen	The screen format is almost the same as that during a measurement, and is used when displaying data in sequence from the head of the address. This screen is displayed when entering recall mode from normal mode (measurement mode).
Address jump screen	This screen is used when jumping to an arbitrary address or when jumping to start/stop save data address, etc.
Time stamp display screen	Displays time stamp (elapsed time) appended to the data currently being displayed.
Statistical data type jump screen	This screen is used when viewing chronological changes for each data type (Max, Min, Avg, σ) when the statistical calculation mode is repeat or single.
Comparator calculation result jump screen	This screen is used when searching for data judged as NO GO by a comparator calculation.

The functions of key operations in recall mode vary according to the screen. The key functions in each screen are as follows. For details, see the explanation of the relevant screen.

Screen \ Key	Normal recall	Address jump	Time stamp display	Statistical data type jump	Comparator calculation result jump
	—	Select the address jump item.	—		
	Increase/Decrease the recall address by one.	Execute an address jump.	Increase/Decrease the recall address by one.	Execute statistical data type jump.	Execute comparator calculation result jump.
	Switch to address jump screen.	Switch to time stamp display screen.	Switch to normal recall screen		
	Jump to corresponding data between Main and Sub for Dual FUNCTION measurement data.				
	Switch to statistical calculation result jump screen.			Select statistical data type.	Switch to statistical calculation result jump screen.
	Switch to comparator calculation result jump screen.				—
	Exit recall mode and return to normal mode (measurement mode).				

4.8.3.1 Normal recall screen

Screen display

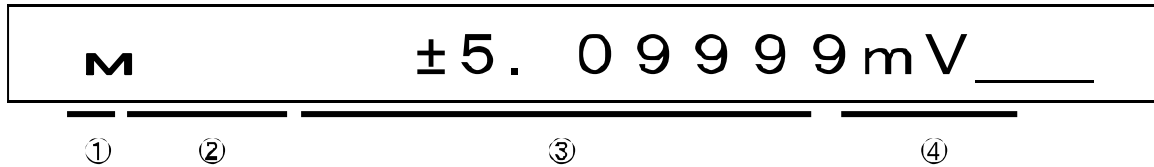

① Channel display

M: measurement data during a Single FUNCTION operation

m: Main side function measurement data during a Dual FUNCTION operation

s: Sub side function measurement data during a Dual FUNCTION operation

② Comparator calculation results or statistical data type

Measurement data when statistical calculation mode is OFF or CONT (continuous)

If the comparator calculation is on, the comparator calculation results will be displayed. When it is off, the screen will be blank.

For the comparator calculation results display, refer to the items on comparator calculations.

Measurement data when statistical calculation mode is Repeat or Cont

The statistical data types, Max, Min, Avg and σ are displayed. The comparator calculation results are not displayed.

③ Measurement value (including sign and multiplier)

④ Unit

When specifying an address for which no data has been saved, a message like the one below will be displayed.

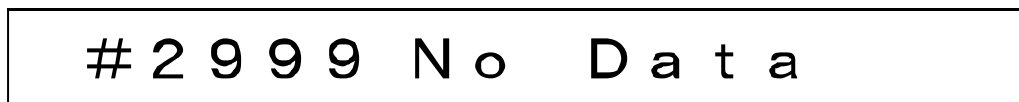

Address

Operation



-  key

This key does not function in the normal recall screen.

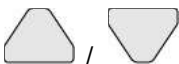

-  keys

The recall address increases/decreases by one each time these keys are pressed.



If the  key is pressed at #2999, the data at #0000 will be displayed. Likewise, when the



 key

is pressed at #0000, the data at #2999 will be displayed.

Measurement Methods

SAVE

- **RECALL** key

The Save key switches the screen to the address jump screen. The recall address is unaffected when the screen is changed.

**ATTR
M ↔ S**

- **M•S-CALC** key

When data is saved during a Dual FUNCTION operation, the data being displayed switches between

Main and Sub. For details, see the section on switching between Main and Sub using the **ATTR
M ↔ S** **M•S-CALC** key.

**MAX
/ MIN**

- **MODE** key

This key switches the screen to the statistical data type jump screen. The recall address is unaffected when the screen is changed.

COMP

- **HI/LO** key

This key changes the screen to the comparator calculation result jump screen. The recall address is unaffected when the screen is changed.

RES

SHIFT

- **(LOCAL) / ENTER** key

Pressing this key exits the recall mode and returns to the normal mode (measurement mode).

4.8.3.2 Address jump screen

Screen display

m # 0 0 0 0 ↓ ± 5 . 0 9 9 9 9 m

①

②

③

④

- ① Channel display

Same as normal recall screen

- ② Recall address

Displays the address (recall address) of the currently displayed data

- ③ Marker for save start/stop

↓ : Displays the first data saved after starting a save operation

↑ : Displays the last data saved after stopping a save operation

— : Displays the data saved between the save start and stop

- ④ Measurement value (including sign and multiplier)

If an address is specified for which no data has been saved, a message like the one below will be displayed.



Address

Operation



-  key

Every time the key is pressed, the jump item changes. The jump items are as follows.

Jump item	Screen display when selected
Channel jump	The channel display blinks
Address jump (1, 10, 100 and 1000)	Of the four digits of the address, the selected digit blinks
Start/Stop marker jump	The save start/stop marker blinks

-  keys

Depending on the selected jump item, the function varies as follows.

Jump item	Screen display when selected
Channel jump	Executes a channel jump; for details see the section on channel jumps
Address jump (1, 10, 100 and 1000)	The specified digit of the recall address increases/decreases by one. If the operation result address is larger than #2999, the address jumps to #0000. Similarly, if the address is smaller than #0000, the address jumps to #2999.
Start/Stop marker jump	Jumps to the nearest start/stop marker (If data with a start/stop marker is overwritten, it will be impossible to identify the correct start/stop marker, so be careful.)



- **RECALL** key

The Save key switches the screen to the time stamp display screen. The recall address is unaffected when the screen is changed.



- **M-S-CALC**key

When data is saved during a Dual FUNCTION operation, the data being displayed switches between

Main and Sub. For details, see the section on switching between Main and Sub using the  **M-S-CALC**key.

Measurement Methods



- **MAX / MIN MODE** key

This key switches the screen to the statistical data type jump screen. The recall address is unaffected when the screen is changed.



- **COMP HI/LO** key

This key changes the screen to the comparator calculation result jump screen. The recall address is unaffected when the screen is changed.



- **RES (LOCAL) / SHIFT ENTER** key

Pressing this key exits the recall mode and returns to the normal mode (measurement mode).

4.8.3.3 Time stamp display screen

Screen display

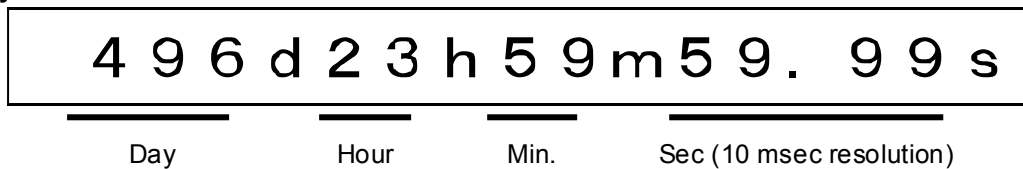

When specifying an address for which no data has been saved, the following will appear.



Operation



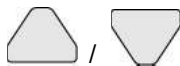

- **AUTO** key

This key does not function in the time stamp display screen.



- **Up / Down** keys

The recall address increases/decreases by one each time these keys are pressed.

If the  key is pressed at #2999, the data at #0000 will be displayed. Likewise, when the  key is pressed at #0000, the data at #2999 will be displayed.



- **SAVE RECALL** key

The Save key returns the screen to the normal recall screen. The recall address is unaffected when the screen is changed..



- M·S-CALC key

When data is saved during a Dual FUNCTION operation, the data being displayed switches between

Main and Sub. For details, see the section on switching between Main and Sub using the  M·S-CALC key.



- MODE key

This key switches the screen to the statistical data type jump screen. The recall address is unaffected when the screen is changed..



- HI/LO key

This key changes the screen to the comparator calculation result jump screen. The recall address is unaffected when the screen is changed.



- (LOCAL) / ENTER key

Pressing this key exits the recall mode and returns to the normal mode (measurement mode).

4.8.3.4 Statistical data type jump screen

Screen display



①

②

③

- ① Channel display

Same as normal recall screen

- ② Statistical data type display

Raw: raw data; data saved when the statistical calculation mode is OFF or CONT

Max: maximum value in N samples

Min: minimum value in N samples

Avg: average value in N samples

σ : standard deviation in N samples

This area is always blinking.

- ③ Measurement value (including sign and multiplier)

When specifying an address for which no data has been saved, a message like the one below will be displayed.



Operation

Measurement Methods



- **AUTO** key

This key does not function in the statistical data type jump screen.

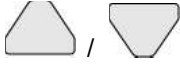

- **↑ / ↓** keys

Focuses on the statistical data type being displayed and jumps. For details, see the section on statistical data type jumps.



- **SAVE** / **RECALL** key

The screen changes to the normal recall screen. The recall address is unaffected when the screen is changed.



- **ATTR M↔S** key

When data is saved during a Dual FUNCTION operation, the data to be displayed switches between Main

and Sub. For details, see the section on switching between Main and Sub using the  **ATTR M↔S** key.



- **MAX / MIN** / **MODE** key

This key changes the statistical data type being displayed. For details, see the section on changing statistical data types.



- **COMP** / **H/L** key

This key changes the screen to the comparator calculation result jump screen. The recall address is unaffected when the screen is changed..



- **RES** / **SHIFT** / **(LOCAL) / ENTER** key

Pressing this key exits the recall mode and returns to the normal mode (measurement mode).

4.8.3.5 Comparator calculation result jump screen

Screen display

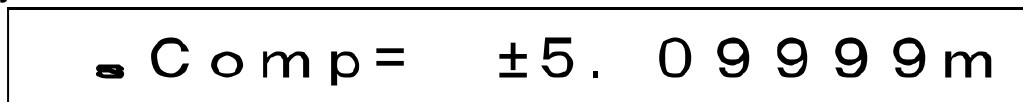

- ① Channel display

Same as normal recall screen

② Comparator calculation result display

- : data when comparator calculation is off
- ▲ : RED level High
- ▲ : YELLOW level High
- : GO
- ▼ : YELLOW level Low
- ▼ : RED level Low

This area is always blinking.

③ Measurement value (including sign and multiplier)

When specifying an address for which no data has been saved, a message like the one below will be displayed.

__ C o m p = __ N o D a t a

Operation



- key

This key does not function in the comparator calculation result jump screen.

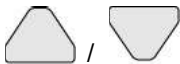

- keys

These keys are used to jump to the address for comparator calculation results that have changed. For details, see the section on comparator calculation results jump.



- key

Changes the screen to the normal recall screen. The recall address is unaffected when the screen is changed.



- key

When data is saved during a Dual FUNCTION operation, the data to be displayed switches between Main



and Sub. For details, see the section on switching between Main and Sub using the key.



- key

Changes the screen to the statistical data type jump screen. The recall address is unaffected when the screen is changed.



- key

This key does not function in the comparator calculation result jump screen.



- key

Measurement Methods

Pressing this key exits the recall mode and returns to the normal mode (measurement mode).

4.8.3.6 Switching between Main and Sub with the selection key

When data is saved during a Dual FUNCTION operation, the respective function measurement values on the

Main side and Sub side are alternatively saved as a set. Every time the  key is pressed, the screen changes to the corresponding Main side and Sub side data.

Switching between Main and Sub when the statistical calculation mode is OFF or CONT

Address	Screen image (for normal recall screen)	
#0000	m 5.09999 mA	← Changes with each key press
#0001	s -3.0999 V	
#0002	m 4.09999 mA	← Changes with each key press
#0003	s 3.0999 V	
.	.	
.	.	

Switching between Main and Sub when the statistical calculation mode is REPEAT or SINGLE

Address	Screen image (for statistical data type jump screen)	
#0000	m Max 5.09999 m	← Changes with each key press
#0001	m Min -3.09999 m	
#0002	m Avg 4.09999 m	
#0003	m σ 0.00005 m	
#0004	s Max 3.0999	
#0005	s Min -3.0999	
#0006	s Avg 1.0000	
#0007	s σ 0.1000	
.	.	
.	.	
.	.	

4.8.3.7 Channel jump

Channel jump is a function that recalls data saved during a Dual FUNCTION operation centered on either the Main side function or the Sub side function. For example, if the function is executed when displaying Main side function data ("m" or "M"), it skips the Sub side function measurement data, and jumps to the next Main side function data. Likewise, when displaying Sub side function data ("s"), it skips to the next Sub side function data.

To change the channel that is being focused on, switch between Main and Sub using the  key.

Channel jump when statistical calculation mode is OFF or CONT

Address	Screen image (address jump screen)	
#0000	m # 0 0 0 0 ↓	5. 0 9 9 9 9 m
#0001	s # 0 0 0 1	3. 0 9 9 9
#0002	m # 0 0 0 2	4. 0 9 9 9 9 m
#0003	s # 0 0 0 3	0. 0 0 0 0
#0004	m # 0 0 0 4	3. 0 9 9 9 9 m
#0005	s # 0 0 0 5	-3. 0 9 9 9
#0006	m # 0 0 0 6	4. 0 9 9 9 9 m
#0007	s # 0 0 0 7 ↑	0. 0 0 0 0
#0008	# 0 0 0 8	No Data
.	.	.
#2999	# 2 9 9 9	No Data

Image of a channel jump operation using the  key

(When pressing the  key, the position jumps in the opposite direction.)

Channel jump when the statistical calculation mode is REPEAT or SINGLE

Address	Screen image (address jump screen)	
#0000	m # 0 0 0 0 ↓	5. 0 9 9 9 9 m
#0001	m # 0 0 0 1	3. 0 9 9 9 9 m
#0002	m # 0 0 0 2	4. 0 9 9 9 9 m
#0003	m # 0 0 0 3	0. 1 0 0 0 0 m
#0004	s # 0 0 0 4	3. 9 9 9 9
#0005	s # 0 0 0 5	-3. 0 9 9 9
#0006	s # 0 0 0 6	0. 0 0 0 0
#0007	s # 0 0 0 7	1. 0 0 0 0
#0008	m # 0 0 0 8	3. 0 0 0 0 0 m
#0009	m # 0 0 0 9	1. 0 0 0 0 0 m
#0010	m # 0 0 1 0	2. 0 0 0 0 0 m
#0011	m # 0 0 1 1	0. 2 0 0 0 0 m
#0012	s # 0 0 1 2	1. 9 9 9 9
#0013	s # 0 0 1 3	-1. 0 9 9 9
#0014	s # 0 0 1 4	0. 0 0 0 0
#0015	s # 0 0 1 5	0. 5 0 0 0
#0016	# 0 0 1 6	No Data
.	.	.
#2999	# 2 9 9 9	No Data

Image of a channel jump operation using the  key

(When pressing the  key, the position jumps in the opposite direction.)

Measurement Methods

4.8.3.8 Statistical data type jump

When measured data is saved with the statistical calculation mode in REPEAT or SINGLE mode, Max, Min, Avg and σ are saved as a set of four data. In the case of a Dual FUNCTION operation, eight data combining Main and Sub side data are saved as a set.

The statistical data type jump is a function that recalls one of these four data (or eight data) types. For example, it is used when tracking the chronological changes of Avg.





Use the **MAX / MIN MODE** key to change the statistical type you wish to jump through.

Statistical data type jump when the statistical calculation mode is REPEAT or SINGLE for a Single FUNCTION

Address	Screen image (for statistical data type jump screen)	
#0000	~rM a x	-4. 48052
#0001	~rM i n	-4. 49707
#0002	~rA v g	-4. 49189
#0003	~r σ	0. 00528
#0004	~rM a x	-4. 39521
#0005	~rM i n	-4. 48557
#0006	~rA v g	-4. 44699
#0007	~r σ	0. 03070
#0008	~rM a x	-4. 19110
#0009	~rM i n	-4. 37975
#0010	~rA v g	-4. 29180
#0011	~r σ	0. 06356
#0012	-	N c D a t a
*		*
*		*
*		*

Statistical data type jump (when focusing on maximum value)

Image of a statistical data type jump operation using the  key

(When pressing the  key, the position jumps in the opposite direction.)

Statistical data type jump when the statistical calculation mode is in REPEAT or SINGLE for a Dual FUNCTION

Address	Screen image (for statistical data type jump screen)
#0000	MAX 4.52444
#0001	MIN 0.22484
#0002	AVG 2.88086
#0003	σ 1.47846
#0004	MAX 0.03148
#0005	MIN 0.03103
#0006	AVG 0.03129
#0007	σ 0.00016
#0008	MAX -0.19580
#0009	MIN -1.49196
#0010	AVG -2.85033
#0011	σ 1.47689
#0012	MAX 0.03135
#0013	MIN 0.03038
#0014	AVG 0.03090
#0015	σ 0.00030
#0016	No Data
.	.
.	.
.	.

Statistical data type jump (when focusing on MAIN side maximum value)

Statistical data type jump (when focusing on SUB side maximum value)

Image of a statistical data type jump operation using the  key

(When pressing the  key, the position jumps in the opposite direction.)

4.8.3.9 Changing the statistical data type

This function is used when changing the statistical type with focus in the statistical data type jump screen. When the statistical calculation mode is in REPEAT or SINGLE mode, Max, Min, Avg and σ are saved as a

set. Pressing the  key in the statistical data type jump screen changes the data displayed in sequence from Max to Min to Avg to σ (then back to Max).

Measurement Methods

Changing the statistical data type

Address	Screen image (for statistical data type jump screen)	
#0000	..M a x 4. 5 2 4 4 4	← ← ← ← Switch statistical data types
#0001	..M i n 0. 2 2 4 8 4	
#0002	..A v g 2. 8 8 0 8 8	
#0003	..σ 1. 4 7 8 4 8	
#0004	..M a x 0. 0 3 1 4 8 m	← ← ← ← Switch statistical data types
#0005	..M i n 0. 0 3 1 0 3 m	
#0006	..A v g 0. 0 3 1 2 9 m	
#0007	..σ 0. 0 0 0 1 3 m	
#0008	..M a x -0. 1 9 5 8 0	← ← ← ← Switch statistical data types
#0009	..M i n -4. 1 9 1 9 8	
#0010	..A v g -2. 8 5 0 3 3	
#0011	..σ 1. 4 7 6 8 9	
#0012	..M a x 0. 0 3 1 3 5 m	← ← ← ← Switch statistical data types
#0013	..M i n 0. 0 3 0 3 8 m	
#0014	..A v g 0. 0 3 0 9 0 m	
#0015	..σ 0. 0 0 0 3 0 m	
#0016	No D a t a	
.	.	
.	.	
.	.	

4.8.3.10 Comparator calculation results jump

When the comparator calculation is on, the jump function jumps to the points that have changed among the comparator calculation results, which are classified into five zones according to two-level threshold values. When the statistical calculation mode is in REPEAT or SINGLE mode, this function cannot be used since the comparator calculation results have not been saved.

Comparator calculation results jump for Single FUNCTION

Address	Screen image (for comparator calculation results jump screen)	
#0000	↖ C o m p = ▼ - 5. 0 0 0 0 0	← ← ← ← ← ← ← ← ← ← ← ← Switch statistical data types
#0001	↖ C o m p = ▼ - 4. 0 0 0 0 0	
#0002	↖ C o m p = ▼ - 3. 0 0 0 0 0	
#0003	↖ C o m p = ▼ - 2. 0 0 0 0 0	
#0004	↖ C o m p = - 1. 0 0 0 0 0	
#0005	↖ C o m p = 0. 0 0 0 0 0	
#0006	↖ C o m p = 1. 0 0 0 0 0	
#0007	↖ C o m p = ▲ 2. 0 0 0 0 0	
#0008	↖ C o m p = ▲ 3. 0 0 0 0 0	
#0009	↖ C o m p = ▲ 4. 0 0 0 0 0	
#0010	↖ C o m p = ▲ 5. 0 0 0 0 0	
#0011	↖ C o m p = _ U. U U U U U	
#0012	_ C o m p = _ N o D a t a	
.	.	
.	.	
.	.	

Image of a comparator calculation results jump operation using the  key

(When pressing the  key, the position jumps in the opposite direction.)

During a Dual FUNCTION operation, the currently displayed results and those on the same side can be searched, while the results on the other side are disregarded.

Measurement Methods

4.9 Time stamp



The multimeter maintains a time stamp from the moment it is switched on. The time stamp can be used when the user wishes to obtain the time that the data save function was activated or the time a peak value occurred in continuous mode in a statistical calculation, and so on.

The specifications of the time stamp are as follows.

Information	Elapsed time
Resolution	10 msec
Maximum value	Approximately 497 days
Reset timing	When the power is turned on When the SYSTEM menu's "TimeInit" is executed When the remote ":TIME:INIT" command is executed When the SYSTEM menu's "SAVE:TimeInit" is on and a save operation is started When the elapsed time has reached the maximum value

4.10 System setup (SYSTEM menu)

The SYSTEM menu contains the various operating parameters of the multimeter. The SYSTEM menu

parameter hierarchy is shown below. The SYSTEM menu settings are confirmed when the  key is pressed. Pressing the  (LOCAL) key cancels all settings, which return to the original values.

